

# Clutch Systems

For passenger cars up to 1,000 Nm

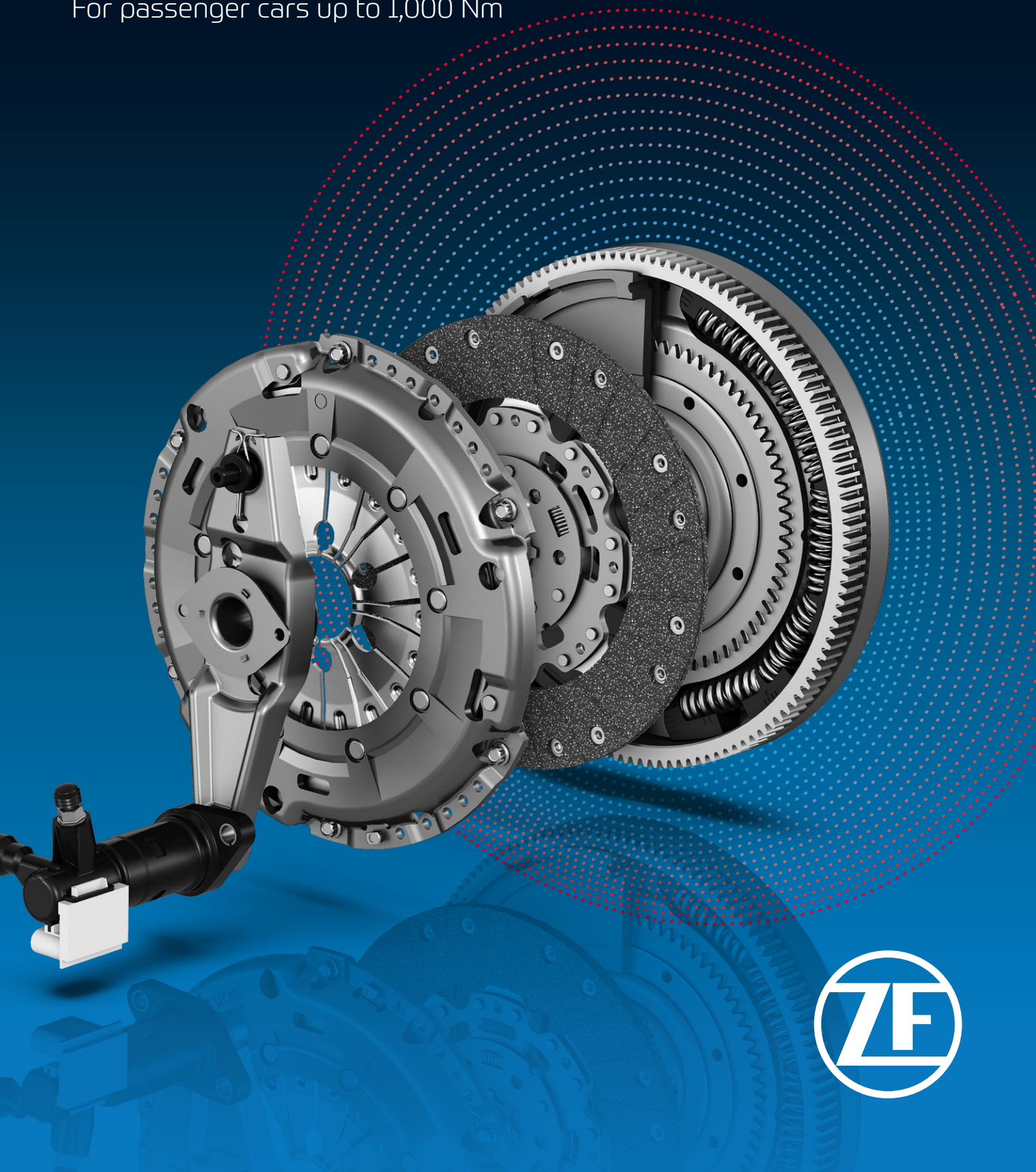

## Contents

# 02

### Products

- 09 Clutch covers –  
Reliable torque transfer
- 10 XTend® – Clutch cover with  
automatic wear compensation
- 12 Clutch disc with torsional damper
- 14 MRU – Mechanical release unit
- 15 Clutch release bearing  
Flexible clutch release bearing
- 16 CbW (Clutch-by-Wire) actuator
- 18 Automated manual transmission –  
Intelligent gear shifting
- 20 Dual mass flywheel DMF –  
Multi-stage vibrational damping

# 01

### Mobility with ZF

- 04 Powertrain components and  
systems for passenger cars  
and light commercial vehicles
- 06 The clutch system –  
Cutting-edge power transmission

# 03

### The Company

- 25 The ZF Group
- 26 Research and development  
to secure mobility

### Innovative and fit for the future

Millions of people around the entire world are driving with car driveline technology from ZF – today and in the future. The products are designed for efficiency and are simultaneously setting standards when it comes to comfort and driving dynamics. Vehicles equipped with ZF technology successfully walk the challenging line between the need to shape individual mobility while also doing everything possible to preserve the environment and resources. It is impossible to imagine automobiles of the future without ZF driveline technology because, with its modern and reliable components, ZF is also paving the way for many trends, such as electrification of the driveline. This culture of innovation as well as the ability to produce components of the highest quality has made ZF a valuable partner in the international automotive industry.

## 01

Mobility  
with ZFPowertrain components  
and systems for passenger  
cars and LCV

Performance – comfort – environmental protection. Powertrain components and systems for passenger cars and light commercial vehicles, developed and delivered by ZF, meet the widespread challenges of the highly complex interface between engine and transmission.



The demands placed on suppliers in the automotive sector are changing dramatically. Increasingly, suppliers are being called upon to integrate components into complex systems – a development task that can only succeed on the basis of close partnerships with vehicle manufacturers. The future will bring continued demands for reduced fuel consumption, emissions, weight and installation space, along with enhanced comfort, safety, and driving dynamics. To meet these goals, innovative solutions and new products are essential.

ZF has taken responsibility here, demonstrating expertise in generating comprehensive solutions with its integrated powertrain systems. In doing so, it consistently pursues a systems approach in developing and manufacturing new products and technologies that represent real advances. ZF provides overall solutions that meet the demands of overall systems.

One example: As a powertrain specialist and manufacturer of electric drives, ZF can also provide superior integration for the full spectrum of hybrid powertrain designs and thus offer production-ready solutions that are already reducing fuel consumption and emissions for the vehicles of tomorrow.

### Clutch system

A complete clutch system generally consists of a flywheel or dual mass flywheel, clutch disc, clutch cover, releaser, and the clutch actuator. Among the numerous criteria used to determine clutch size and clamp load configuration, maximum engine torque and the resulting friction energy are especially significant.

The greater the clamp load, the smaller the friction radius can be. The diameter should be as small as possible, because it greatly affects clutch weight and cost. But the clutch disc also has to be large enough to handle thermal loads and facing wear.

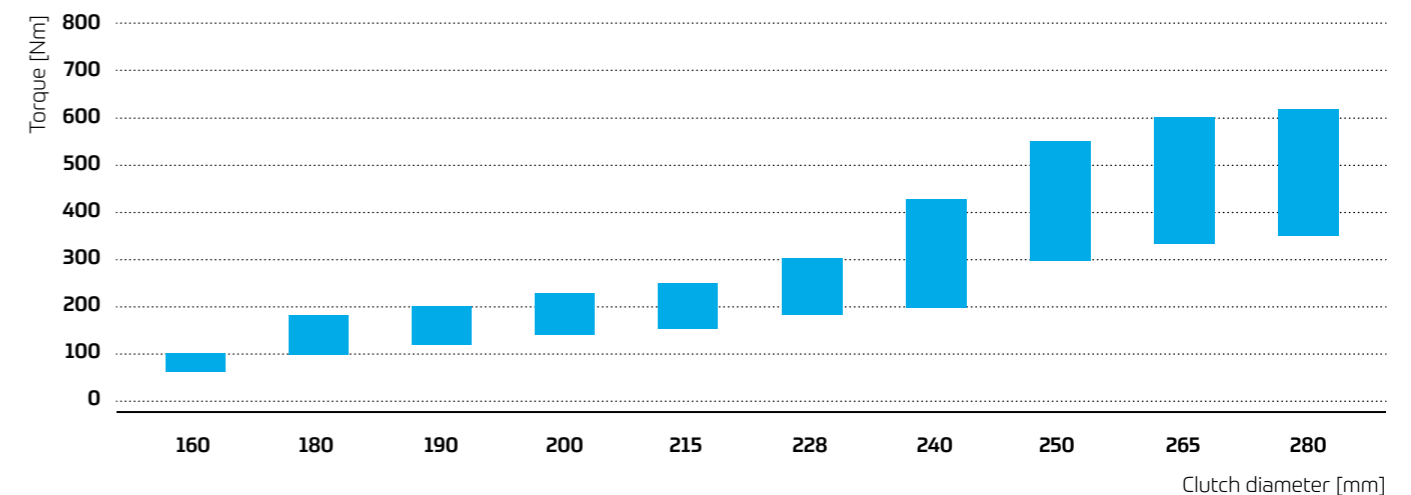

# The clutch system – Cutting-edge power transmission

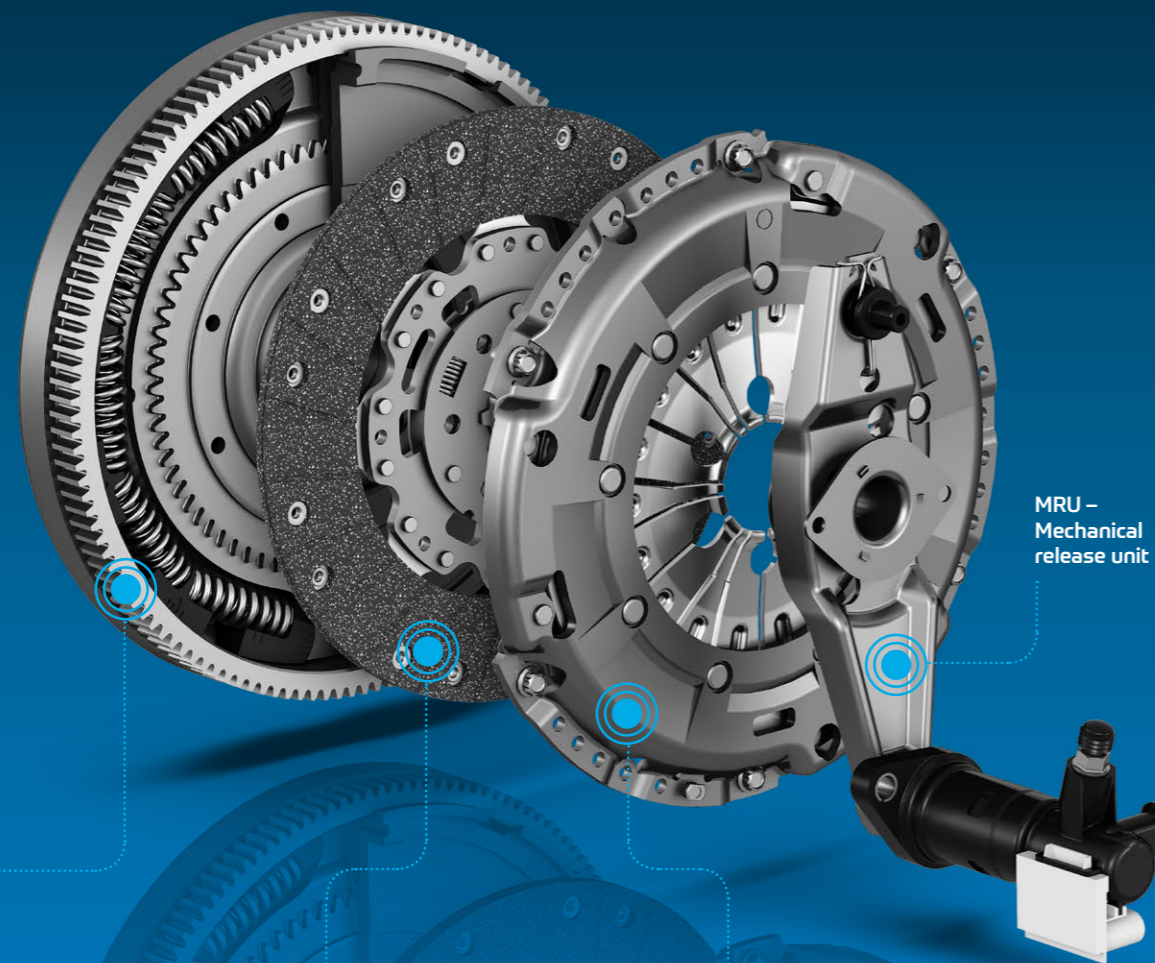

Dual mass flywheel DMF  
or mechanical torsional  
damper

Clutch disc

Clutch cover

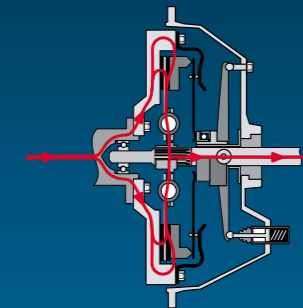
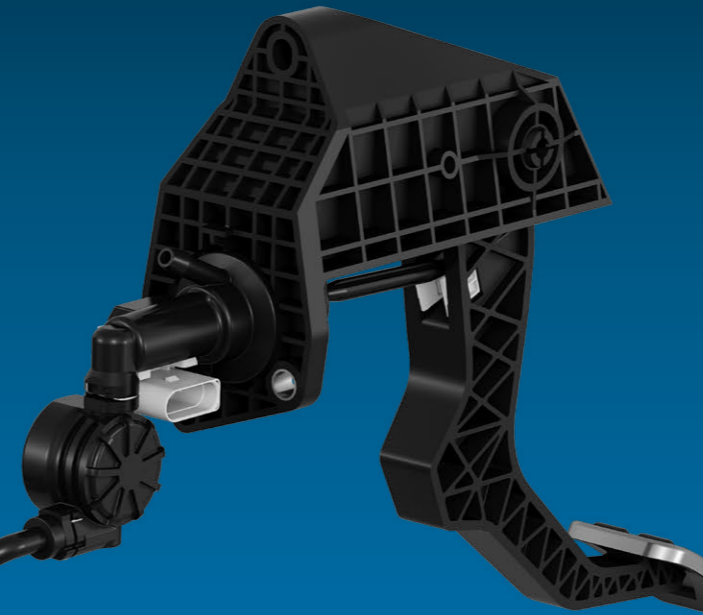

Power flow – engaged

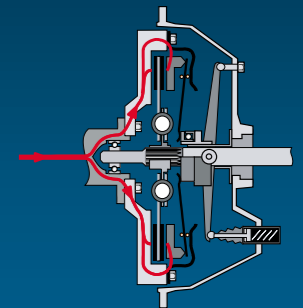

Power flow – disengaged



#### Benefits

- High torque capacity, compact dimensions
- Low release forces thanks to high degree of efficiency
- Simple design
- Proven technology
- Long service life
- Low weight

The technical demands placed on modern clutch systems are many and varied. They include rapid and reliable control of torque transfer, ergonomic operation, maximum service life with no loss in comfort, constant pedal forces, vibrational damping, and minimum installation size.

ZF clutch systems for manual transmissions consist of components that have proven themselves millions of times and that meet the highest standards in all categories. Thanks to customized application engineering, the complete system can be ideally adapted to every vehicle. Moreover, products are technically advanced to such a degree that very little adjustment and development work is needed. Favorable clutch/actuator system prices, combined with the benefits of reduced fuel consumption, mean that clutches and manual transmissions remain a standard feature of small and medium-sized cars as well as commercial vehicles in Europe.

## 02

## Products



## Clutch covers – Reliable torque transfer

### The technology

The clutch cover transmits engine torque via the clutch disc to the transmission input shaft. The clutch cover is bolted securely to the engine flywheel and consists essentially of a metal housing and a diaphragm spring with integrated actuation levers. This spring presses the axially displaceable pressure plate against the clutch disc and the flywheel when the clutch is engaged.

Its characteristic force curve determines the actuation forces needed to release the clutch. Vibrations, torque, and friction-induced heat – the clutch is subjected to some of the highest levels of stress in the powertrain. The spring must perform reliably after many thousands of shifts, even when the inevitable systems-based wear on the clutch facings in every vehicle alters the load/travel configuration.



Pull-type clutch cover



Push-type clutch cover

# XTend® – Clutch cover with automatic wear compensation

## The task

Although clutch facings have undergone substantial improvement in terms of quality and service life, they are still subject to normal wear, even if the vehicle is operated with care. Reduced facing thickness considerably influences the forces within the clutch system. Release and clamp loads rise, and thus the necessary pedal forces as well. XTend® is the ideal solution to counter wear and the associated negative effects on the powertrain. XTend® clutch covers are suitable for all vehicles with high mileage and clutch loads.

## The technology

XTend®, the clutch cover with automatic wear compensation, decouples facing wear from the movement of the diaphragm spring. The compensation mechanism constantly registers the reduction in facing thickness, and securely off sets this distance by rotating an adjustment ring. This keeps the force ratios constant, and extends the service life because the facings can accommodate additional wear. Another advantage of XTend® lies in its design: It reduces the axial dimensions of the clutch system needed to accommodate normal facing wear.



### Benefits

- Constant pedal forces throughout the entire service life
- Flexible adjustment to individual vehicle requirements
- Resistance to extreme temperatures, dirt, and aging
- Smaller axial dimensions
- Easy to install and service

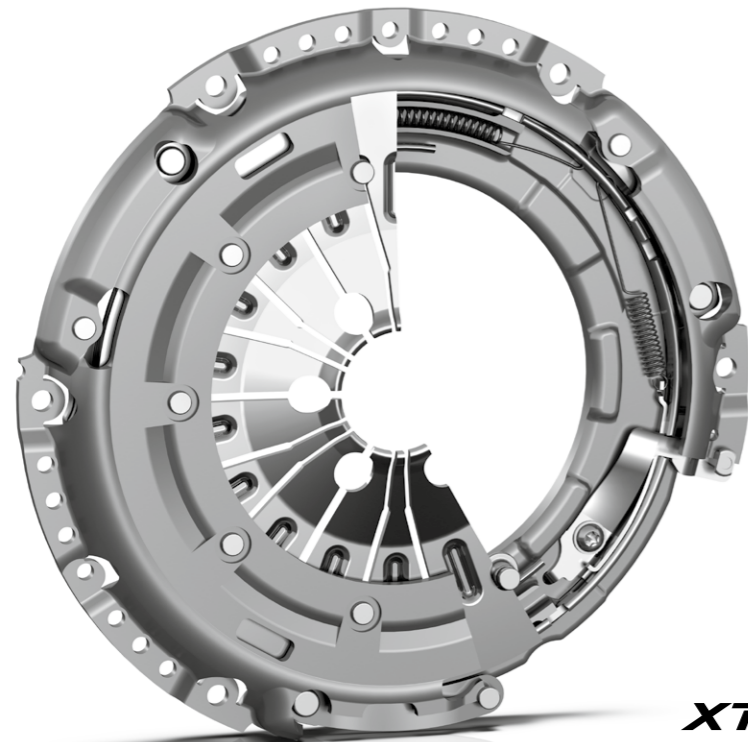

**XTEND®**

XTend® clutch cover

## Clutch in new condition

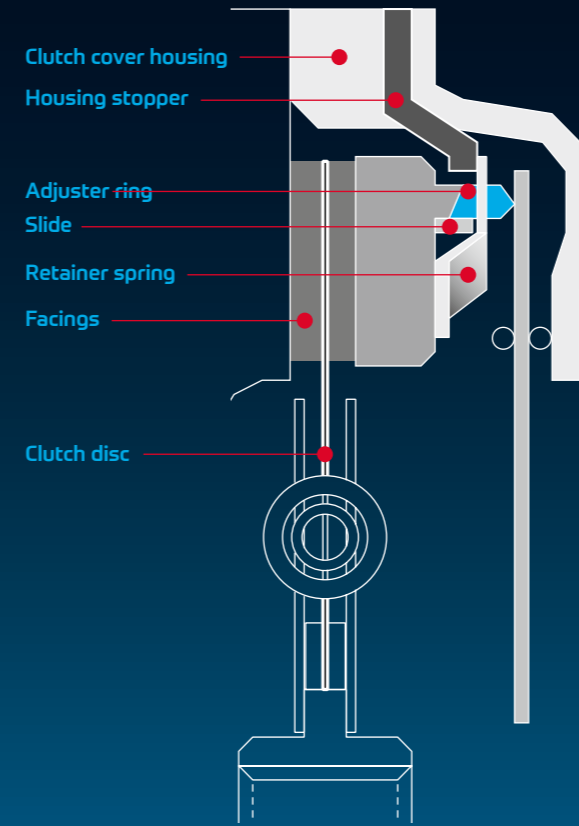

## Clearance adjustment during clutch action

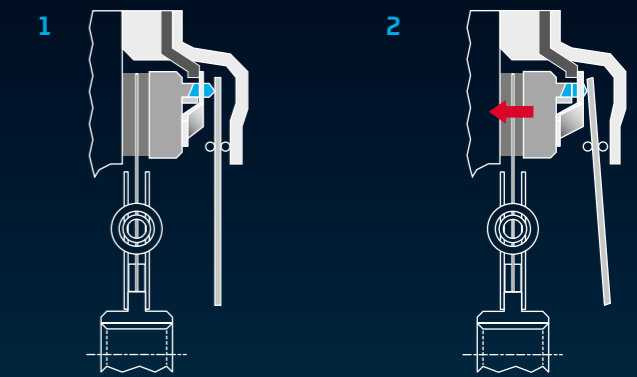

Clutch in new condition

When wear occurs, the clutch cover moves toward the flywheel.

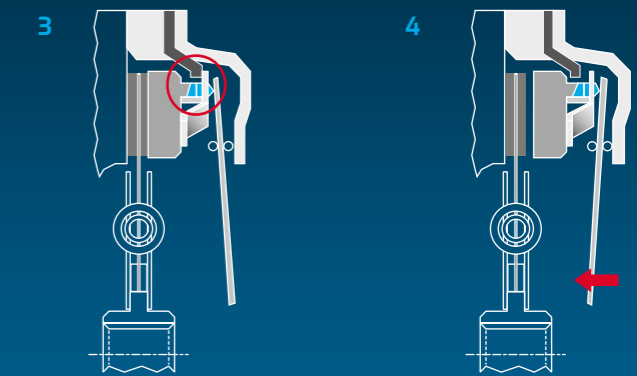

The stopper raises the retainer spring from the adjuster rings, the slide fills the gap.

When the clutch is released ...

## Principle of wear compensation

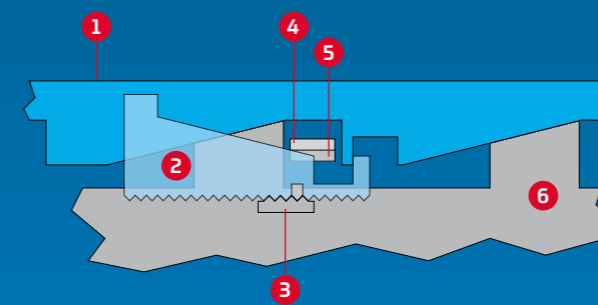

- 1 Adjuster ring
- 2 Toothed slide
- 3 Toothed disc
- 4 Retainer spring
- 5 Stopper
- 6 Pressure plate

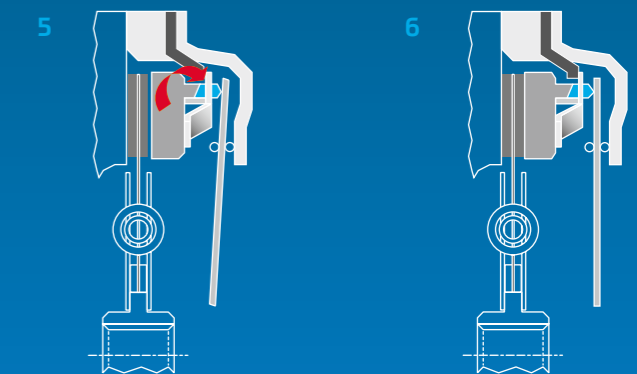

... the adjuster ring compensates for the wear.

The clutch has compensated for the wear and the system is reset to its initial force and path settings.

# Clutch disc with torsional damper

## The task

Ignition-induced irregularities in rotational speed and rapid load alterations generate vibrations in the powertrain, which in turn cause disturbing noises in the vehicle body and unpleasant rattling in the transmission. Modern engines are featuring smaller displacements and supercharging (down-sizing) in order to reduce fuel consumption. These engines generate high levels of torque at low rpm levels (down-speeding). This constellation of engine characteristics leads to an increase in torsional vibrations. Yet drivers continue to demand higher performance from their damping systems.

## The technology

The torsional damper integrated in the clutch disc is the main element for adjusting torsional rotation properties throughout the powertrain, from the combustion engine to the wheels. This effective vibrational damping system consists of a friction unit and spring sets for both driving and idling. Coil springs positioned in windows allow a limited degree of rotation between the crankshaft and the transmission input shaft. Torsional dampers are individually tuned because each engine/transmission aggregate has its own characteristics. The resulting superior spring and damping characteristics generate outstanding decoupling qualities.



### Benefits

- Complex individual characteristics
- Compact construction
- Low inertia
- Modular design

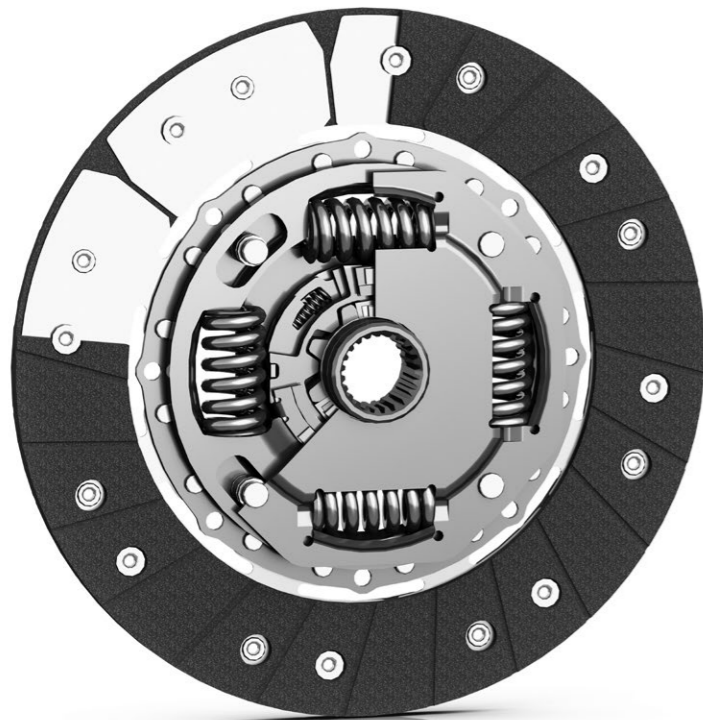

### Clutch disc with torsional damper

The torsional dampers are tuned for the characteristics of each vehicle model. Thanks to multistage main dampers and extra preliminary dampers, engine vibrations are effectively minimized both when idling and driving.

## Vibrational damping in a torsional damper

Torque and angular travel

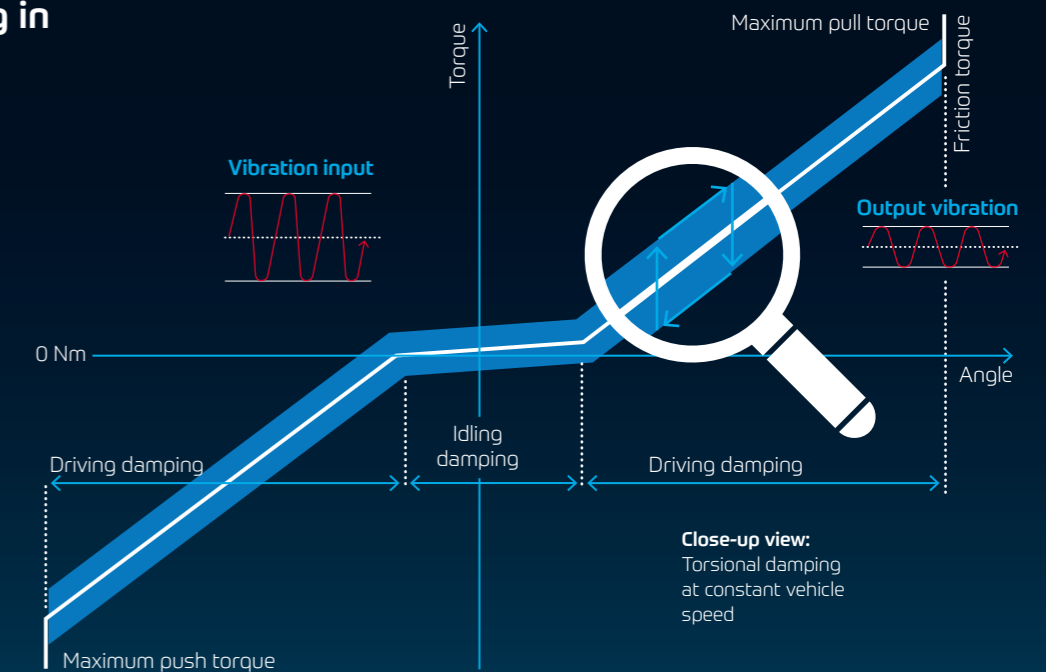

## ZF clutch facings – all-rounder under the most extreme conditions

# 450°C

Peak temperature through friction

### Challenge: tribological characteristics

The clutch facing is subject to high frictional load during clutch engagement. The frictional load particularly occurs during starting but also during normal driving operation. Temperatures of up to 450°C may develop at times. Even under such extreme conditions, the clutch facing ensures a sufficiently high frictional coefficient to prevent fading and slipping of the clutch and, as a result, stranding of the vehicle. In addition to the stable friction coefficient, the clutch facing offers high wear resistance.

### Challenge: mechanical characteristics

Due to the high rotational speed and the acceleration of a combustion engine, the clutch facing requires very good mechanical characteristics. Strong acceleration leads to an accelerating force which results in high tensile shear in rotation direction. High rotational speed leads to high radial force which results in high tractive forces in radial direction. The minimum burst strength of the clutch facing is correspondingly high. This is still the case when the facing has been partly pre-damaged by thermal load. The clutch facing is still able to bear high pressure as the diaphragm spring presses it strongly against

the engine flywheel via the pressure plate during clutch engagement.

### Challenge: heat dissipation thanks to high thermal conductivity

The clutch facing requires the highest possible heat conductivity to quickly dissipate friction-induced heat to the neighboring metal parts, thereby avoiding thermal damage of the facing.

### Challenge: comfort

The friction facings allow fine dosing of the engine torque during the starting phase which, in combination with the cushion springs, make smooth starting possible. Particularly unpleasant clutch grab during starting (vibrations in the range of 10Hz) is prevented.

### Challenge: material composition

ZF clutch facings consist of a number of well-matched materials: Yarns of glass or polymer fibers as well as copper or brass wire, embedded in a mixture of resin, rubber, and filler materials. They are lead-free and are manufactured in environmentally friendly processes. They comply with EU regulations for vehicle recycling.

# MRU – Mechanical release unit

## The task

The mechanical release unit connects the hydraulic clutch actuation system with the diaphragm spring on the clutch cover assembly. The MRU must ensure absolute noiselessness and uncompromising reliability over its entire service life. In addition, optimized system rigidity is required to impart a subjectively “good feel” for the pressure point to the driver.

For this purpose, ZF offers its customers a unit that minimizes assembly work as only one module needs to be installed. In addition, this solution makes it possible for the customer to resort to a system on which all individual parts have been adapted to each other perfectly with regard to efficiency, robustness, and service life.

## The technology

The mechanical release unit consists of a ready-to-fit component assembly. The first component is the guide sleeve. It is bolted into the bell housing and ensures axial guidance of the clutch release bearing. High requirements regarding surface quality and roundness of this component ensure friction-optimized motion of the clutch release bearing on the guide sleeve. The release lever/release fork transmits the release stroke from the slave cylinder to the clutch release bearing. One side of the release lever is supported on the slave cylinder; the other side is supported on the bell housing via a pin that is pre-installed on the MRU.

The clutch release bearing is the transfer element between the rotating clutch and the stationary actuation system. Optimized synthetic materials for the sliding sleeve and a friction-optimized interface between the thrust ring and the diaphragm spring minimize the increase in hysteresis over the entire service life.

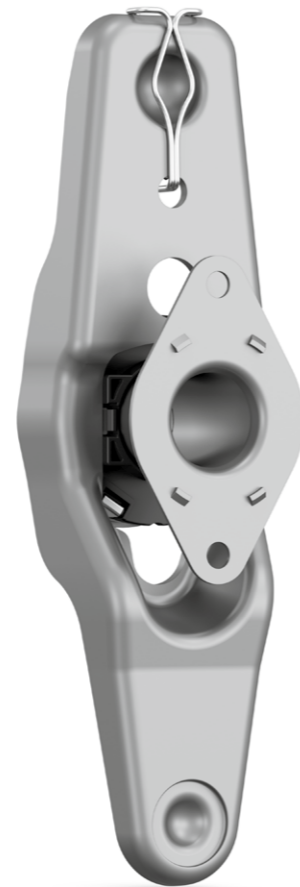

Mechanical release unit

# Clutch release bearing

## The task

The clutch release bearing is the transfer element between the rotating clutch and the stationary actuation system. Absolute noiselessness and uncompromising reliability under any kind of operating condition must be ensured over its entire service life. With the clutch release bearing it is possible to compensate for a potential assembly- or tolerance-related off set.

## The technology

The clutch release bearing is part of a modular system in which all components are ideally matched. Special plastics which have been modified with regards to wear, friction, and form stability are used for the sliding sleeve. The inner and outer ring of the clutch release bearing are high-precision, high-strength steel parts. In order to guarantee reliable lubrication of the ball-bearing grooves over the entire service life, only special grease is used. To reduce friction between the diaphragm spring in the pressure plate and the inner ring of the clutch release bearing, a plastic thrust washer can be fitted.

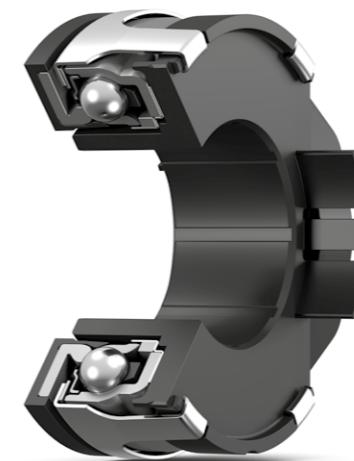

Clutch release bearing

# Flexible clutch release bearing

## The task

The flexible clutch release bearing is the transfer element between the rotating clutch and the stationary actuation system. Absolute noiselessness, uncompromising reliability over the entire service life, and optimum elimination of rotational irregularities must be ensured by the precession-inhibitory clutch release bearing. The ever increasing efficiency optimization on modern drivelines results in an increasing susceptibility to vibration phenomena. The flexible clutch release bearing decouples vibrations that originate from the engine and are transmitted to the clutch system, thus reducing driveline vibrations.

## The technology

The flexible clutch release bearing is equipped with a special ball groove which makes it possible to tilt the inner ring relative to the outer ring. By using balls in the clutch release bearing, this system provides a low friction, dynamic compensation for any diaphragm spring precession. This precession of the clutch release bearing results in a significant reduction of pedal and driveline vibrations, thus increasing comfort for the driver.

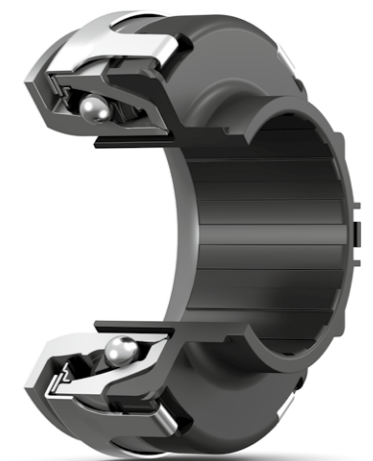

Flexible clutch release bearing

# CbW (Clutch-by-Wire) actuator

## The task

Ever increasing regulations regarding resource-efficient drivelines require new ideas for vehicles with conventional manual transmissions. Clutch-by-wire technology makes it possible to save fuel, reduce CO<sub>2</sub> emissions, and enhance comfort at the same time. A clutch actuator opens and closes the clutch. Combined with integrated control electronics, this allows to open the driveline during rolling operation, to turn off the engine and, thus, to save fuel and reduce CO<sub>2</sub> emissions. If torque is needed again after so-called coasting, the engine is started automatically and the driveline is closed.

## The technology

The clutch-by-wire clutch actuator developed by ZF is equipped with a brushless DC motor and an integrated clutch control unit. This control unit enables to integrate various functions, such as coasting, start & stop, creeping, and stall protection for combustion engines. The clutch-by-wire clutch actuator is a further development of the tried and tested ZF AMT clutch actuators. Both electrohydraulic and electromechanical solutions can be offered. The applied mechanical solutions in the clutch-by-wire clutch actuator provide for high efficiency and low power requirements.

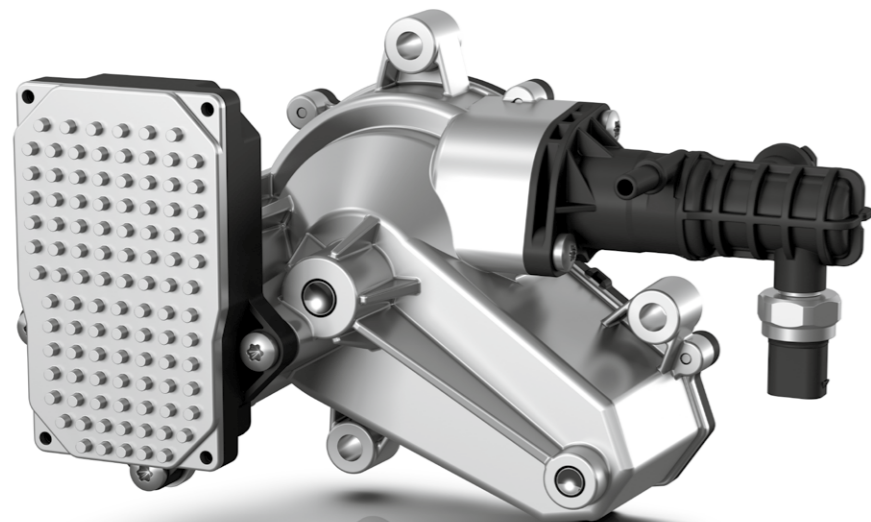

CbW actuator

**10%**

**Consumption reduction**  
Clutch-by-wire systems can reduce fuel consumption and consequently CO<sub>2</sub> emissions by up to ten percent.



### Benefits

- Compact design
- Integrated control unit (CCU) at actuator
- Available as electromechanic or electrohydraulic actuator
- Possibility of saving fuel and reducing CO<sub>2</sub> emissions

Clutch-by-wire comprises a manual transmission with an automated clutch actuation system. The automation makes it possible to actuate the clutch pedal without mechanical linkages – the decision to engage or disengage the clutch is communicated by wire to an actuator.

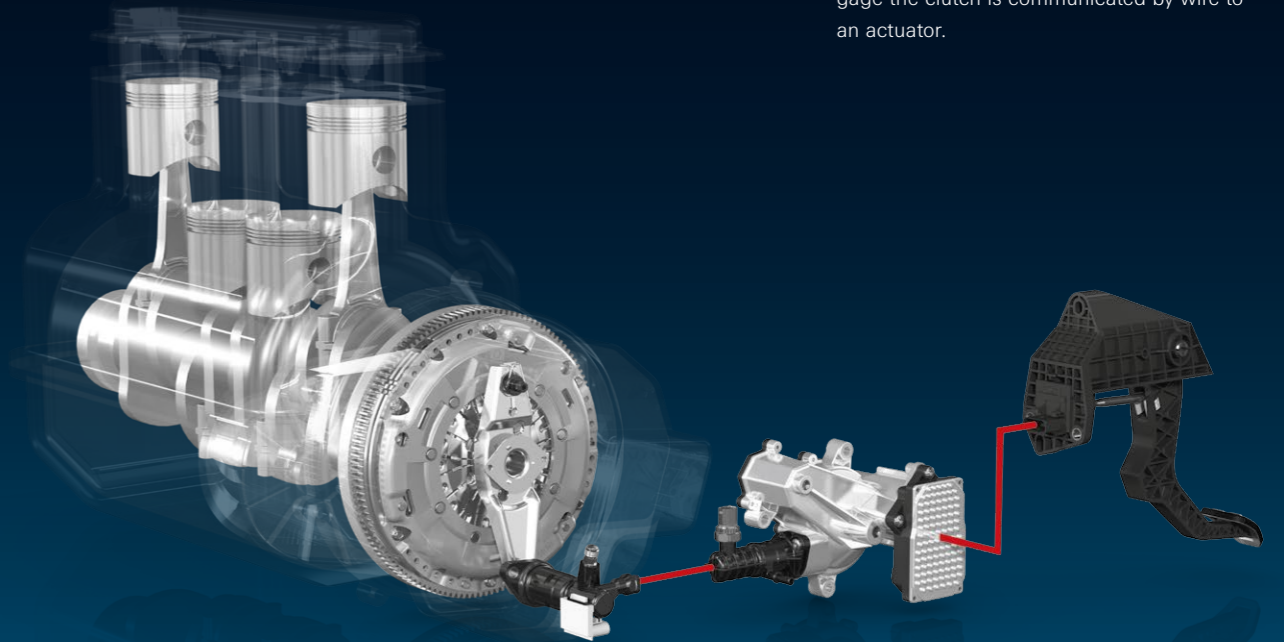

### Additional functions

In addition to the coasting function for emission and consumption reduction, the additional functions shown are also available. The assistance functions offer a considerable comfort gain in the driveability. In the development of these functions, care was taken that on the one hand, the driver receives the greatest possible support and, on the other hand, the greatest possible system penetration through the clutch pedal. These functions are configurable and scalable according to the customer's requirements, and can be integrated as possible function packages in a clutch-by-wire system.

**Optimized pedal characteristic curve**



**Start-off assistant**



**Engaging assistant**



**Stall protection**



**ABS support**



**Creeping function**



**Congestion assistant**



**Coupling protection**



**Overspeed protection**



**Underspeed protection**



# Automated manual transmission – Intelligent gear shifting

## The task

To best meet demands on the part of drivers, the automobile industry, and legislators for lower fuel consumption and emissions, it is essential to raise the level of efficiency in the powertrain. Moreover, components from ZF can also be used to automate manual transmissions and thus improve comfort in vehicle categories that cannot have automatic transmissions for reasons of weight, installation space, or cost. ZF provides the overall system with actuators, TCU, software and shifters from a single source, and can thus assume leadership of the system development process. Complete expertise with the system and its interfaces means that the individual actuation components can be adapted optimally to vehicle designs.

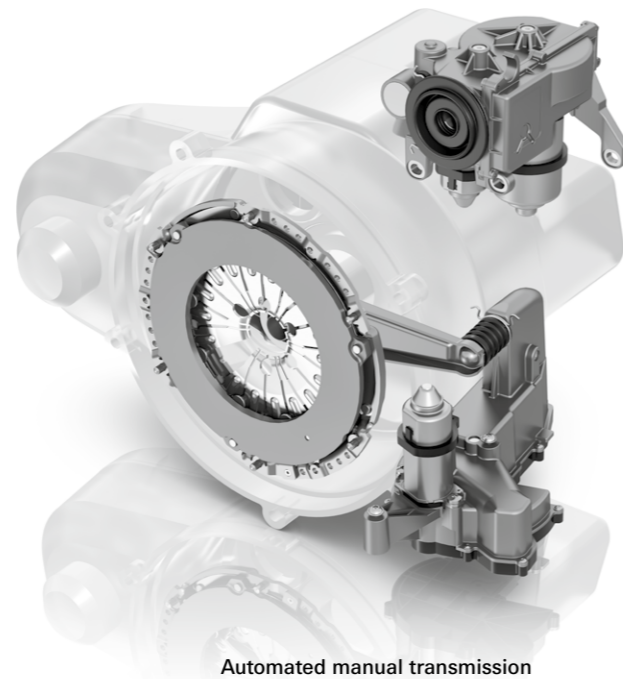

Automated manual transmission

## The technology

In automated manual transmissions, electromechanical or hydraulic actuators take over the clutch and shift actions. In either case, individual driving pleasure is not diminished because drivers can decide whether they want to use the automatic mode or shift manually using switches or levers.

With their optimized shift strategies, automated manual transmissions reduce torque interruption to a minimum. Sensors register and convey all the relevant information to the control system. Using this data, the system calculates the shift points and controls the shift and clutch processes automatically. The technology even intervenes in driving operations to improve safety – such as automatically interrupting the torque flow briefly to counter the risk of skidding. Automation components can also be used in start-stop as well as hybrid applications. Buyers of standard cars are already enjoying greater comfort thanks to ZF components for automated manual transmissions.



### Benefits

- Full driving comfort – no clutch actuation, no shifting
- Prevents error during shifting
- Lower cost and weight, smaller space claim than automatic transmissions
- Allows manual shifting and thus individual driving styles
- Separate programs for sportive driving, bad weather conditions or slippery or icy road conditions and trailer use
- Reduced fuel consumption due to electronically optimized shift points and high mechanical efficiency

## Schematic diagram of an electromechanical system automation

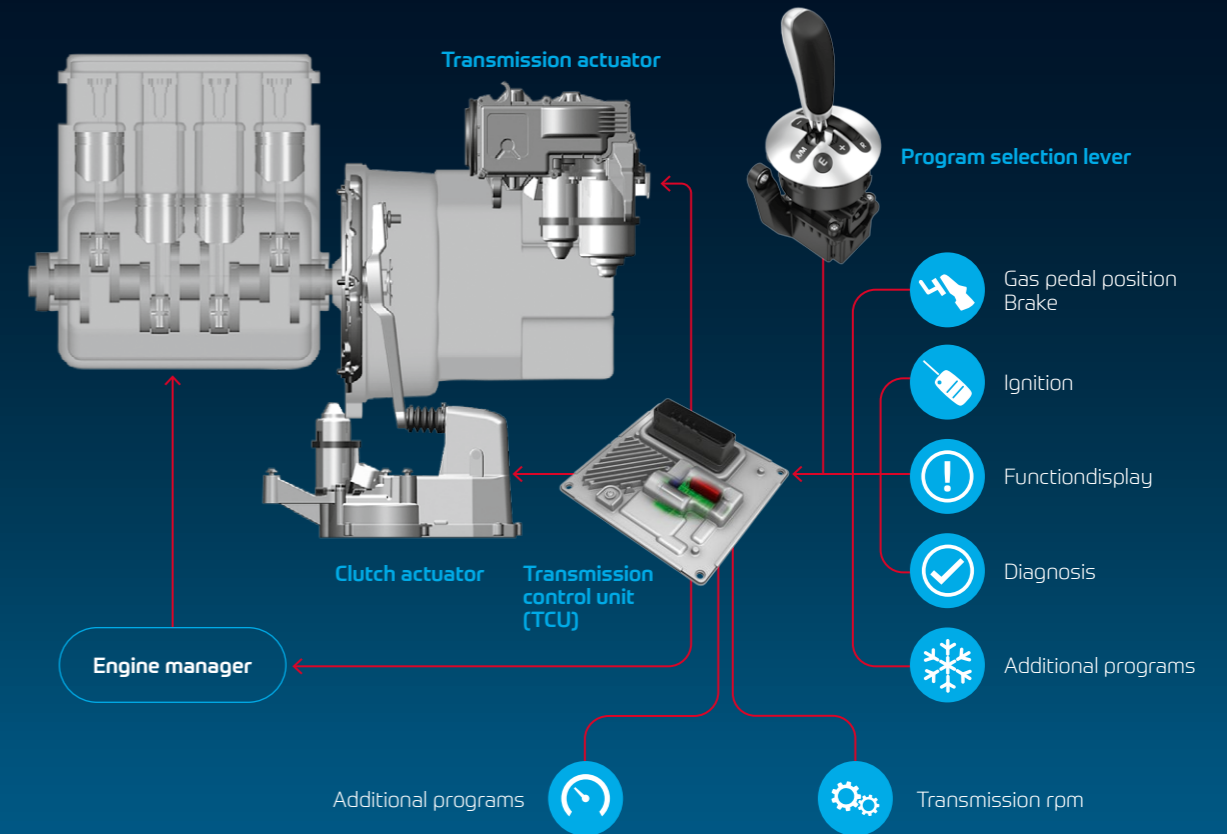

## MT/AMT comparison

Parameters	MT	AT	Comment
Fuel consumption	+/-	++	Fuel consumption reduced by shifting to automatic mode at the optimum point in time
Emissions	+/-	++	CO <sub>2</sub> emissions lowered by shifting to automatic mode at the optimum point in time
Costs	++	+	Favorably priced automation alternative compared to other common systems (dual clutch, automatic transmissions)
Driving comfort	+	++	Driver and passenger comfort markedly increased by shifting to automatic mode at the optimum point in time

# Dual mass flywheel DMF – Multi-stage vibrational damping

ZF's DMF impresses with its modular design of the compression spring offering a solution for various torsional vibrational problems in the vehicle. Supplemented by a rpm-adaptable damper, the torsional vibration caused by the internal combustion engine is excellently decoupled.

## The task

Passenger car engines with optimized fuel-consumption levels are becoming ever more powerful despite smaller displacements and fewer cylinders. To drive on less fuel, the engine's useable rpm range has been shifted toward the idling range. This has led to a marked rise in rotational irregularities in the combustion engine. To continue to provide rumble-free driving and to protect the powertrain from harmful vibrations, effective vibrational damping is needed. The highly effective DMF models from ZF provide optimum torsional damping.

## The technology

The dual mass flywheel is installed between the engine and the transmission along with the clutch cover and clutch disc. The DMF and the MTD both consist of a primary and a secondary mass, which are connected by a lubricated spring set. The primary mass is bolted to the crankshaft and carries the starter ring gear. The primary and secondary masses are mounted such that they can rotate independently. The spring set has a modular design, which allows characteristic curves to be varied and optimized. It consists of compression springs as well as



### Single-row DMF

For engines with low and medium torque ranges up to 400 Nm. Straight compression springs. Multi-stage characteristic curve.



### Double-row DMF

For engines with medium and high torque ranges > 350 Nm. Additional inner damper for high driving comfort.

**Mechanical torsional damper**

For engines with low and medium torque ranges up to 350 Nm. Additional friction unit with speed-dependent effect.

**DMF with rpm-adaptable damper**

Swing-mounted flyweights for vibrational damping. Application for highest comfort requirements.

**DMF TD with direct output**

Application for CVT, dual clutch, and hybrid transmissions.

compression spring guide elements which are made of high-strength plastic.

The properties of the polyamide plastics are selected by application-specific compounding. All DMFs from ZF have multi-stage torsional characteristic curves. This is achieved by combining different quantities of compression springs with different rigidities. The soft initial stage ensures excellent engine starting and stopping behavior. Subsequent harder stages provide effective torsional vibration decoupling and sufficient overload protection at normal driving speeds.

A further improvement in torsional vibration damping is achieved by a DMF with a double-row spring set. The second spring set is located radially within and downstream from the first, which substantially decreases the DMF's torsional rigidity. The inner damper's compression springs operate with low friction at both high engine rpm and torque levels. A DMF with an rpm-adaptable damper provides excellent torsional vibration decoupling. The rpm-adaptable damper operates on the DMF's secondary mass and is located within the outer spring set. The rpm-adaptable damper vibrates inversely to the rotational irregularity remaining from the DMF spring set, which nearly eliminates residual rotary vibration amplitudes. This additional vibrational damping enables vehicles to be driven at high loads without annoying noises from idling speeds on up.

**Benefits**

- Less noise
- Easier to shift gears
- Outstanding vibration damping throughout the entire rpm range
- Easily adjusted to vehicle designs
- Smooth start/stop performance
- Long service life
- Smaller dimensions
- Pull and push-type clutches possible
- Reduced fuel consumption because vehicles can be operated at lower rpm levels

# DMF at a glance

## Vibrational decoupling

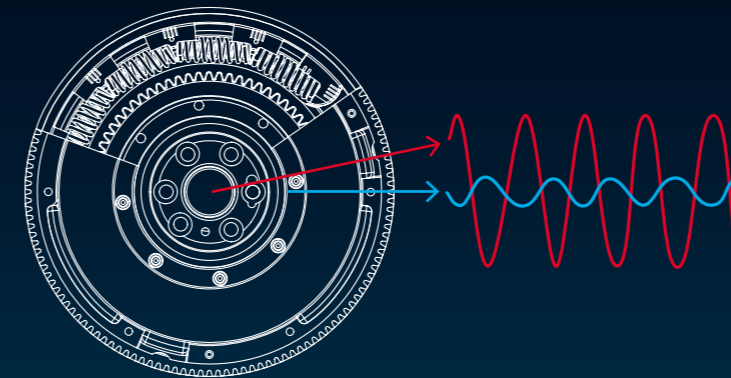

The flywheel is divided into a primary and a secondary mass. Together with the spring set, it effectively isolates torsional vibrations.

## Comparison of clutch vs. DMF

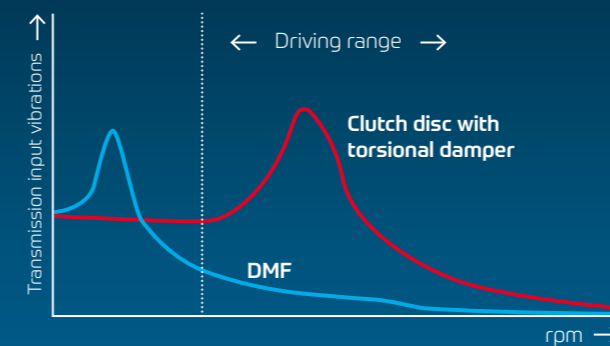

For a torsional damper in the clutch disc, the resonance rpm lies in the lower engine speed range, but for a dual mass flywheel it lies well below the engine idling speed.

## Two and three-stage DMF characteristic curves

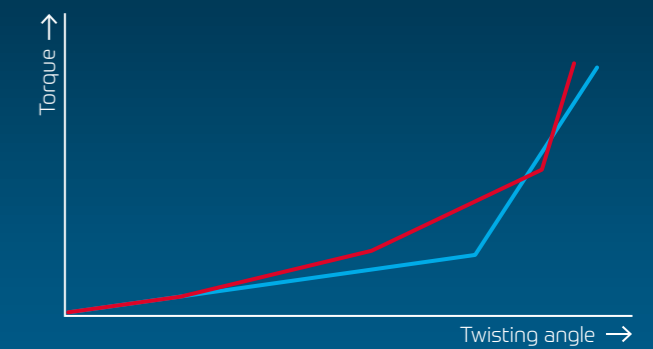

A typical DMF characteristic curve. It starts with a soft initial stage, followed by considerably harder stages. The first stage features a minimum degree of stiffness in order to keep the DMF natural frequency low.

## Comparison of vibration damping

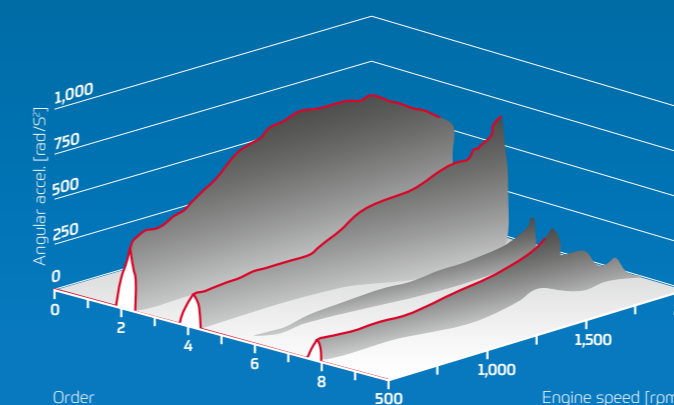
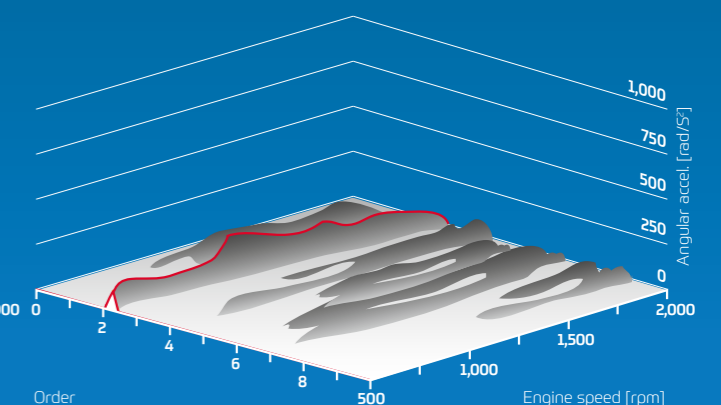
**Clutch disc with torsional damper****Dual mass flywheel**

## 03

## The company



Share **Responsibility** Globally  
 Improve **Efficiency** Permanently  
 Leverage **Opportunities** Jointly  
 Demonstrate **Reliability** Daily

## The ZF Group

## Shaping the future responsibly

ZF Friedrichshafen is a global leader in driveline, chassis and safety technology and its broad portfolio of products and services is advancing mobility in the automobile, truck and industrial technology sectors. Specializing in highly efficient driveline technologies, ZF has expanded into urban mobility solutions which help protect all road users. With its intelligent mechanical systems that combine innovative automotive components and advanced digital technology, ZF is allowing vehicles to see, think and act.

The company is playing a major role in implementing key technologies that are shaping the megatrends of efficiency, safety and autonomous driving in the global automotive industry. Its engineers are currently working on the next generation of advanced safety systems to help enable autonomous driving for both cars and trucks.

ZF focuses on highly efficient driveline solutions with products for E-Mobility and develops solutions for urban mobility and assistance for vulnerable road users. We work on autonomous and remote driving technology for trucks to make the transportation of goods more efficient and safe.

ZF has a global workforce of around 137,000 employees with approximately 230 locations in some 40 countries. In 2016, ZF achieved sales of €35.2 billion. The company supports sustainable business practices and believes in the importance of corporate social responsibility. It annually invests about six percent of its sales in research & development – ensuring continued success through the design and engineering of innovative technologies. ZF is one of the largest automotive suppliers worldwide.

# Research and development to secure mobility

Innovations are not an end in themselves, they must pay off: For manufacturers, fleet owners, and drivers, but also for the environment and society. Each new development must prove itself among the conflicting priorities of these criteria.

The ZF Group draws upon an international network of development centers. Each year, ZF invests approximately five percent of its sales in R&D. With success, because innovative products from ZF set the standards for state-of-the-art technology – again and again.

Development work at ZF is organized according to decentralized and corporate functions. The divisions and business units focus on markets and product expertise, ensuring customer-centered, competitive technological product development. Corporate R&D works with a strong emphasis on basic research and theory, and supports the operational development departments in the divisions.

## Groundbreaking innovations

Over the past years, this partnership has produced product innovations that have since become benchmarks in the industry: Just some examples are the 8-speed automatic transmission for cars as well as hybrid transmissions and hybrid management for cars and commer-

cial vehicles, or the modular TraXon transmission system for commercial vehicles. Groundbreaking innovations from ZF are in use today not just in passenger cars and commercial vehicles on the road, but also in all kinds of craft on the water and in the air.

What's more, the innovative power of ZF is set to increase in the future. Proof of this is already provided by the number of patents pending: A look at the statistics of the German Patent and Trademark Register shows that ZF is among the top ten applicants for patents – at eye level with many large automotive manufacturers. Each year, the research departments successfully complete more than 10,000 projects, covering the full range from basic research to product applications. This high project volume is necessary to ensure mobility in the future. The trend toward hybrid solutions already shows that green drive technology is very complex. The same goes for pure electric drives and lightweight design engineering. Currently, ZF engineers are conducting pioneering work on alternative materials, broader approaches in design and testing, and new production processes.



**ZF Friedrichshafen AG**

Ernst-Sachs-Strasse 62  
97424 Schweinfurt  
Germany

Phone +49 9721 98-0  
Fax +49 9721 98-2290  
[www.zf.com](http://www.zf.com)



[twitter.com/zf\\_group](https://twitter.com/zf_group)  
[facebook.com/zffriedrichshafen](https://facebook.com/zffriedrichshafen)  
[youtube.com/zffriedrichshafenag](https://youtube.com/zffriedrichshafenag)